

# WebOP-2057V

## 5.7" QVGA Operator Panel with WebOP Designer Software



### Features

- Various LCD sizes (3.5", 5.7", 7", 8", 10.4", 12.1")
- Supports ARM9-based CPUs with 70~200MHz and 4~16MB flash memory
- Supports RTC, battery backup RAM, and Ethernet-based operator panels
- Supports runtime data downloads through Serial, Ethernet, USB
- Supports adjustable brightness controls via touch panel
- Reliable firmware for 24/7 operation
- Supports Windows XP/7/Vista-based WebOP Designer development tool
- Easy to switch one application to different LCD sizes in seconds
- Supports vertical and horizontal application screen rotation
- Supports over 300 PLC industrial communication protocols
- Communicates with up to four types of devices
- Panel mounting for machinery

### Introduction

To satisfy the stringent standards required in the automation market, especially packaging, label slitting, and motion-based robot dispensing, Advantech offers the WOP-2000V series which are designed with ARM9-based RISC CPU with 70~200MHz and 4~16MB flash memory for application software. The WOP-2000V series also support a variety of LCD size from 3.5" to 12.1" for different applications involving the use of PLCs, motion/thermal controllers, inverters and sensors. WebOP Designer is a software development kit which helps create application solutions for labor-saving, improved efficiency of manufacturing and easy control of every machine in the factory. The WOP-2000V series is bundled with WebOP Designer offering an outstanding price performance ratio for various markets such as conventional operator panels, HMI + Low mini SCADA systems, and HMI + communication gateways.

### Specifications

#### General

- **Certifications** CE, BSMI, CCC, UL, FCC Class A
- **Dimensions (WxHxD)** 187 x 145.7 x 45 mm (7.36" x 5.73" x 1.77")
- **Cut-out Dimensions** 175 x 132.5 mm (6.89" x 5.21")
- **Front Panel Thickness** 6mm
- **Operating System** HMI RTOS, WebOP Designer
- **Power Supply Voltage** 24V<sub>DC</sub> ±10%
- **Power Consumption** 15W
- **Enclosure Housing** Plastic
- **Mounting** Panel
- **Weight (Net)** 0.65 kg (1.42 lbs)

#### System Hardware

- **CPU** RISC 32bits, 70MHz
- **Battery Backup Memory** 128KB
- **Flash Memory** 4MB
- **Power-On LED** Yes
- **Communication LED** COM1 and COM2
- **Front USB Access** No

#### Communication Interface

- **COM1** RS-232/422/485 (DB9 Female)
- **COM2** RS-232/422/485 (DB9 Female & 5-Pin Connector)
- **COM3** None
- **Ethernet (RJ45)** 10/100-BaseT (for N1AE model)
- **I/Os**
  - USB Client No
  - USB Host No
  - Micro-SD Slot No

#### LCD Display and Touchscreen

- **Display Type** QVGA TFT LCD
- **Display Size** 5.7"
- **Max. Resolution** 320 x 240
- **Max. Colors** 265 colors
- **Luminance (cd/m<sup>2</sup>)** 400
- **Backlight Life** LED, 20,000 hrs
- **Dimming** Adjustable by touch panel
- **Touchscreen** 4 wire analog resistive

#### Environment

- **Operating Temperature** 0 ~ 50°C (32 ~ 122°F)
- **Storage Temperature** -20 ~ 60°C (-4 ~ 140°F)
- **Humidity** 10 ~ 95% RH @ 40°C, non-condensing
- **Ingress Protection** Front panel: IP65
- **Vibration Protection** Operating, random vibration 1 Grms (5 ~ 500 Hz)

### Ordering Information

- **WOP-2057V-S1AE** 5.7" QVGA, 4MB, RS-232/422/485
- **WOP-2057V-N1AE** 5.7" QVGA, 4MB, RS-232/422/485, Ethernet

## Dimensions

Unit: mm

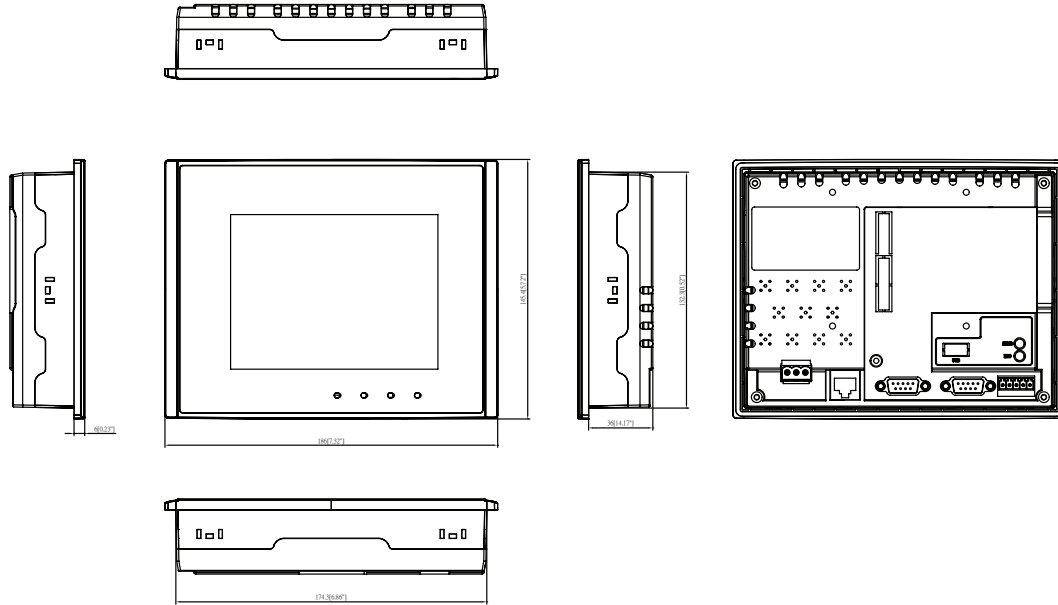

Panel Cut-out Dimensions: 175 x 132.5 mm (6.89" x 5.21")

## Accessories

- **CWOP-P2HFM-AD12E** PC to HMI program download cable, DB9/2m
- **CWOP-P2HAB-ADU2E** PC to HMI program download cable, USB/2m
- **PWR-247-AE** 24 V 50 W AC-DC Power Adapter
- **1702002600** Power Cable US Plug 1.8 M
- **1702002605** Power Cable EU Plug 1.8 M
- **1702031801** Power Cable UK Plug 1.8 M
- **1702031836** Power Cable China/Australia Plug 1.8 M

## Rear View

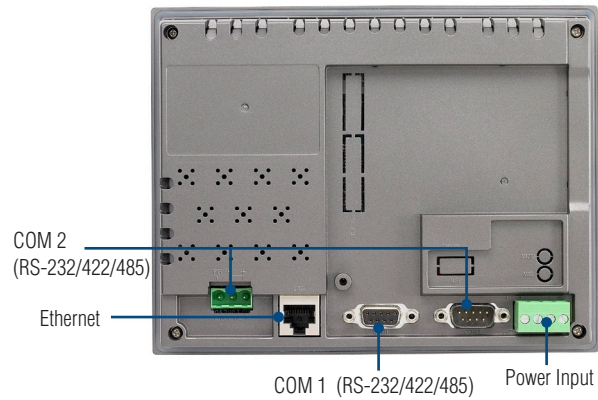

## Communication Links

### Direct Link

#### 1-to-1 Connection

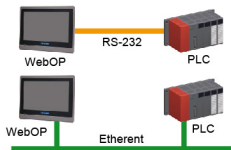

#### 1-to-N Connection

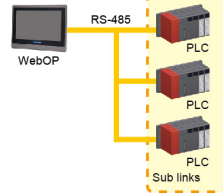

#### N-to-1 Data Sharing Connection

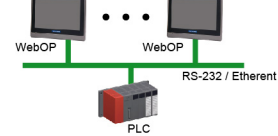

### In-Direct Link

#### 2-to-1 Connection



#### N-to-1 Connection

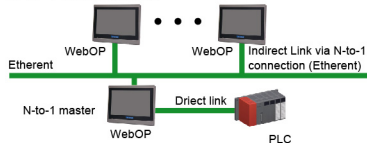

#### 2-to-1 Transparent Connection

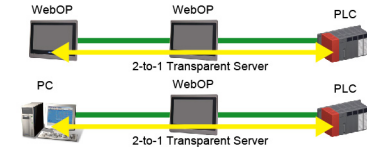



[www.L-TronDirect.com](http://www.L-TronDirect.com)

800-830-9523

[info@L-Tron.com](mailto:info@L-Tron.com)

596 Fishers Station Dr | Victor, NY | 14564 | Suite 1 A

[www.L-Tron.com](http://www.L-Tron.com)

